



TAI-SAW TECHNOLOGY CO., LTD.

No. 3, Industrial 2nd Rd., Ping-Chen Industrial District,
Taoyuan, 324, Taiwan, R.O.C.

TEL: 886-3-4690038 FAX: 886-3-4697532

E-mail: tstsales@mail.taisaw.com Web: www.taisaw.com

Approval Sheet For Product Specification

Issued Date: 5/4/2007 (REV. NO: 1)

Product Name: SMD 7.0x5.0 11.0592MHz Crystal Unit

TST Parts No.: TZ1151A

Customer Parts No. : _____

Company: _____
Division: _____
Approved by: _____
Date: _____

Checked by: _____ C.C.Hsu

Approval by: _____ Robert Chang

Date: _____ 5/4/2007



TAI-SAW TECHNOLOGY CO., LTD.

No. 3, Industrial 2nd Rd., Ping-Chen Industrial District,
Taoyuan, 324, Taiwan, R.O.C.

TEL: 886-3-4690038 FAX: 886-3-4697532

E-mail: tstsales@mail.taisaw.com Web: www.taisaw.com

SMD 7.0x5.0 11.0592MHz Crystal Unit

MODEL NO.: TZ1151A

REV. NO.: 1

Features:

- Surface Mount Seam Weld Package
- Good Frequency Perturbation and Stability over temperature

RoHS Compliant
Lead free
Lead-free soldering

Description and Applications:

Surface mount 7.0x5.0 mm crystal unit for customer

Electrical Specifications:

TZ1151A	Specification
Nominal Frequency	11.059200 MHz
Mode of Oscillation	Fundamental
Storage Temperature Range	-20°C to +70°C
Operating Temperature Range	-10°C to +60°C
Frequency Stability over Operating Temperature Range	+/-5 ppm (referred to the value at 25°C)
Frequency Make Tolerance (FL)	+/-5 ppm @ 25°C +/- 3°C
Equivalent Series Resistance (ESR)	40Ω max.
Nominal Drive Level	300 uW
Load Capacitance (CL)	16.0pF
Frequency Shift after Reflow	+/-1 ppm
Aging	±3.0 ppm/year @25°C
Insulation Resistance	500 MΩ min./DC 100V
Marking	Laser marking

Mechanical Dimensions (mm):

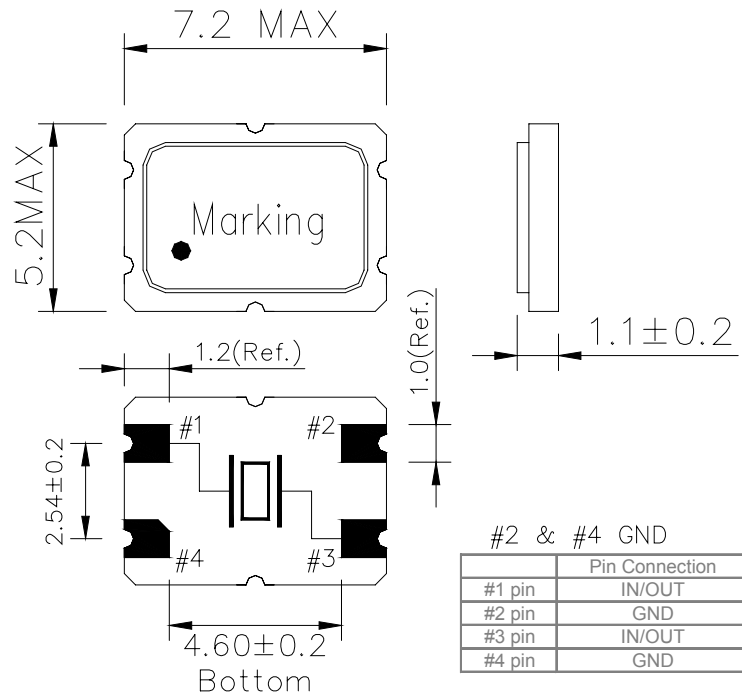

Marking:

Line 1: Frequency (11.059)

Line 2: TST Logo + Crystal Product Code + Date Code+ A

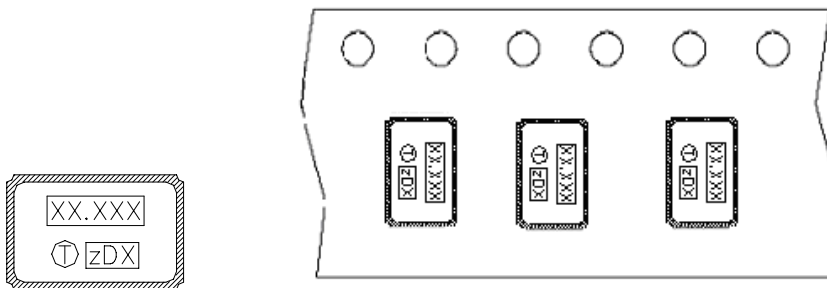

Product Code Table

Year	2001	2002	2003	2004
	2005	2006	2007	2008
Product Code	Z	z	<u>Z</u>	<u>z</u>

Date Code Table

WK01	WK02	WK03	WK04	WK05	WK06	WK07	WK08	WK09	WK10	WK11	WK12	WK13
A	B	C	D	E	F	G	H	I	J	K	L	M
WK14	WK15	WK16	WK17	WK18	WK19	WK20	WK21	WK22	WK23	WK24	WK25	WK26
N	O	P	Q	R	S	T	U	V	W	X	Y	Z
WK27	WK28	WK29	WK30	WK31	WK32	WK33	WK34	WK35	WK36	WK37	WK38	WK39
a	b	c	d	e	f	g	h	i	j	k	l	m
WK40	WK41	WK42	WK43	WK44	WK45	WK46	WK47	WK48	WK49	WK50	WK51	WK52
n	o	p	q	r	s	t	u	v	w	x	y	z

Reel Dimensions (mm):

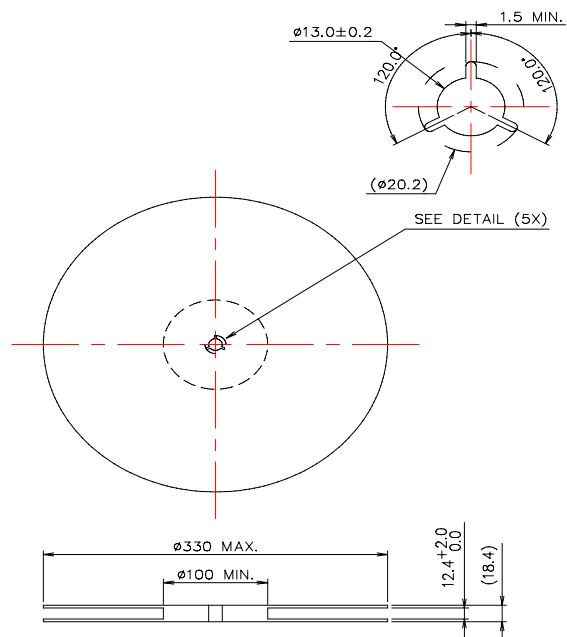

Tape Dimensions (mm):

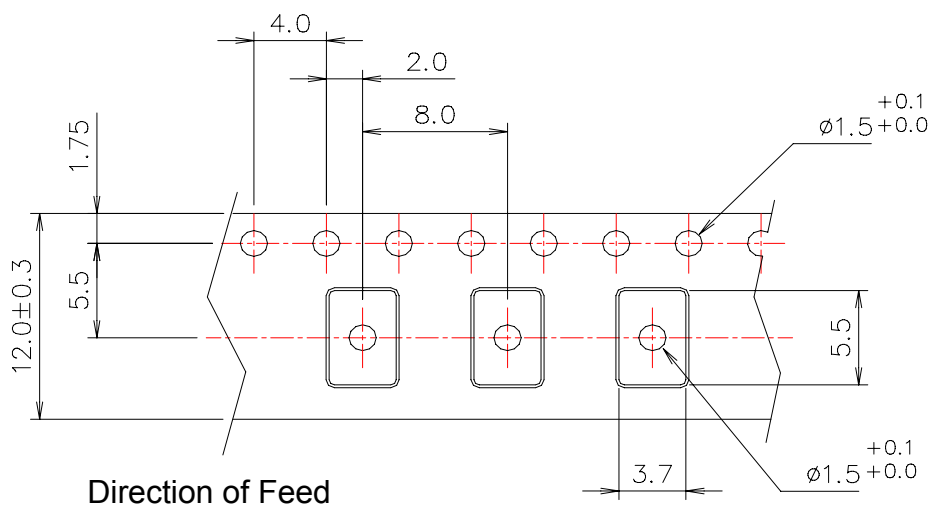

[NOTE]:

1. Unless otherwise specified tolerance on dimension $\pm 0.1 \text{ mm.}$
2. Material: conductive polystyrene with color black
3. 10 pitch cumulative tolerance $\pm 0.2 \text{ mm.}$

Reflow Profile:

